



V420 C FI



SCHEDA TECNICA RIASSUNTIVA TECHNICAL SUMMARY

| | |
|---|----------------------------|
| Produzione oraria Kg <i>Hourly production Kg</i> | / |
| Produzione oraria LT <i>Hourly production LT</i> | / |
| Produzione minima ciclo LT <i>Minimum cycle production LT</i> | / |
| Produzione massima ciclo LT <i>Maximum cycle production LT</i> | / |
| Miscela introdotta ciclo Kg <i>Mixture introduced cycle Kg</i> | / |
| Miscela introdotta ciclo Lt <i>Mixture introduced cycle Lt</i> | / |
| Pastorizzazione ciclo <i>Pasteurization cycle</i> | / |
| Crema ciclo <i>Cream cycle</i> | / |
| Tensione standard <i>Standard voltage</i> | 230V~50Hz 230V~50Hz |
| Potenza W <i>Power W</i> | 200 200 |
| Condensazione <i>Condensation</i> | A A |
| Dimensione nette mm L/P/H <i>Net dimension mm W/D/P</i> | 495x495x670 495x495x670 |
| Peso netto Kg <i>Weight Kg</i> | 34 34 |

DIMENSIONI (mm) DIMENSIONS (mm)

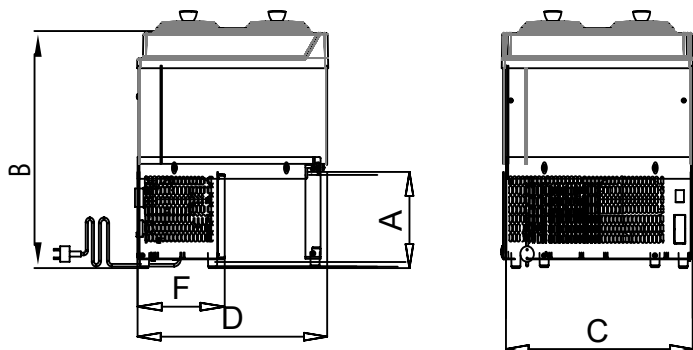

| A | B | C | D | F | G | L | S | T | Z |
|-----|-------------|-----|-----|-----|------|---|---|---|---|
| 240 | 658/588/616 | 495 | 491 | 215 | 1062 | | | | |